

2-Wire Door Station User Manual

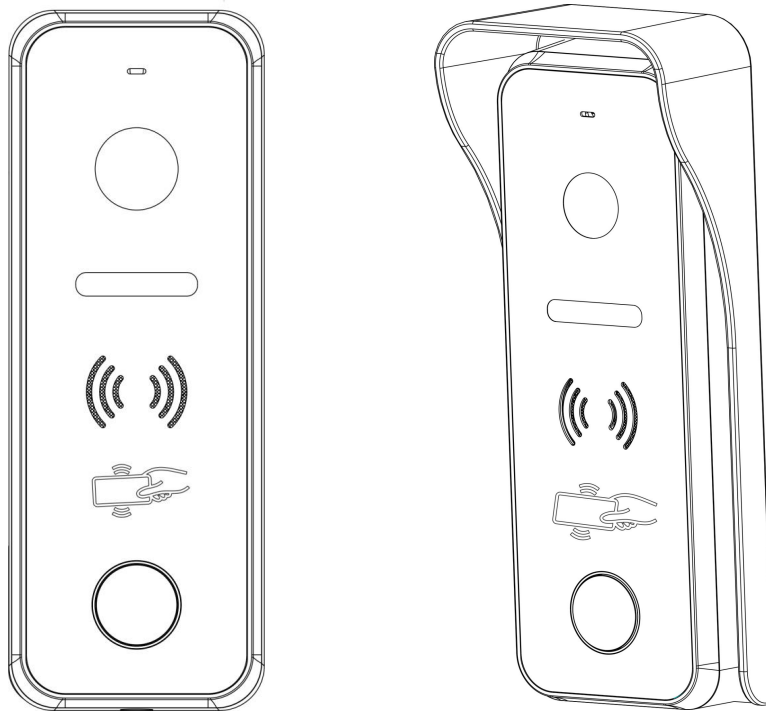

Thank you for purchasing our products.

Please read this User Manual carefully before using this product.

Index

1. Product Features and Main Function	1
2. Name and the Function of Each Part	1
2.1 Names of Each Part	1
2.2 Terminal Description	2
3. Packing List	3
4. Wiring Diagram	3
4.1 Electrical Lock Wiring Diagram	3
4.2 Wiegand Unlock Wiring Diagram	4
4.3 System Wiring Diagram	5
4.31 Use DC24V, 1A Adapter as System Power Supply	5
4.311 One Monitor with One Door Station	5
4.312 Two Monitors with One Door Station.....	5
4.313 Four Monitors with One Door Station(Maximum)	6
4.314 Three Monitors with Two Door Stations(Maximum)	7
4.32 Use DC24V, 1A DIN Rail Power as System Power Supply	8
4.321 One Monitor with One Door Station	8
4.322 Two Monitors with One Door Station.....	9
4.323 Four Monitors with Two Door Station(Maximum)	9
4.324 Five Monitors with One Door Station(Maximum)	9
4.33 Multi Door Stations Connection	11
5. Installation Guide	13
5.1 Cautions	13
5.2 Surface Mounted	13
5.3 Surface mounted with angle bracket (tilted 30°).....	14
5.4 Wire Distance.....	14
6. RFID Access Control Management	16
6.1 Access State.....	16
6.2 Register Access Card(125KHz ID card).....	16
6.3 Check/Manage Registered Card Information	16
6.4 Backup Registered Card Information.....	16
6.5 Restore Registered Card Information.....	16
7. Specification	17

1. Product Features and Main Function

- ◆ Digital 2 wire, nonpolar and easy wiring
- ◆ Support 2 locks
- ◆ 110°wide viewing angle
- ◆ 1080P HD color CMOS camera
- ◆ Night vision with automatic lumens adjustment
- ◆ Support surface mounted with a rain hood, or surface mounted with a 30 degree angle bracket
- ◆ Aluminum housing with IK07 & IP66 high protection level
- ◆ Slim design, suit for install at a narrow place
- ◆ Support Wiegand unlocking
- ◆ Support connecting an exit button
- ◆ Support door status checking

2. Name and the Function of Each Part

2.1 Names of Each Part

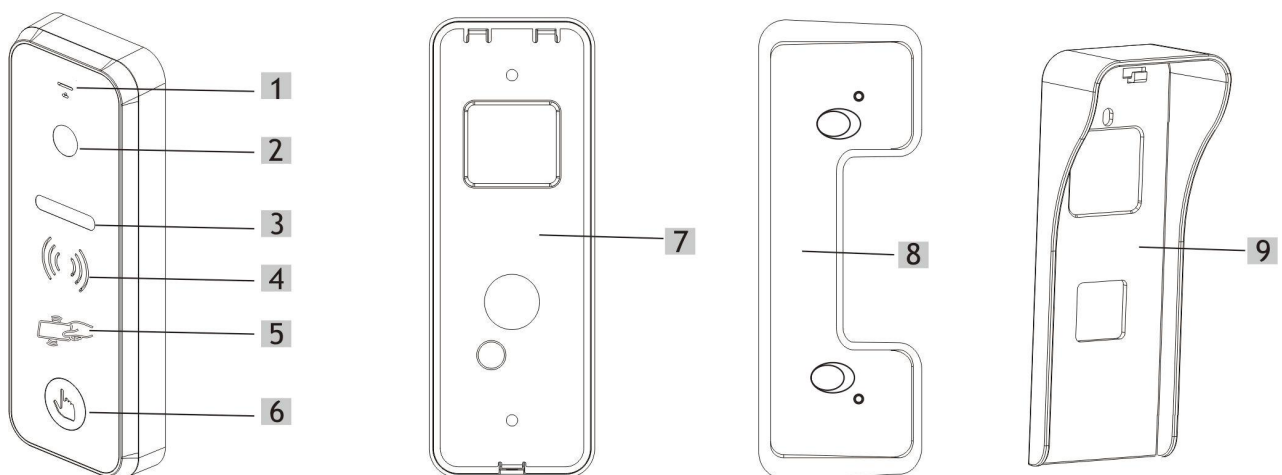

- (1) Microphone
- (2) Camera
- (3) Infrared light for night vision
- (4) Speaker
- (5) Card reading area
- (6) Call button
- (7) Mounting bracket(Optional)
- (8) Angle bracket(Optional)
- (9) Rain hood(Optional)

2.2 Terminal Description

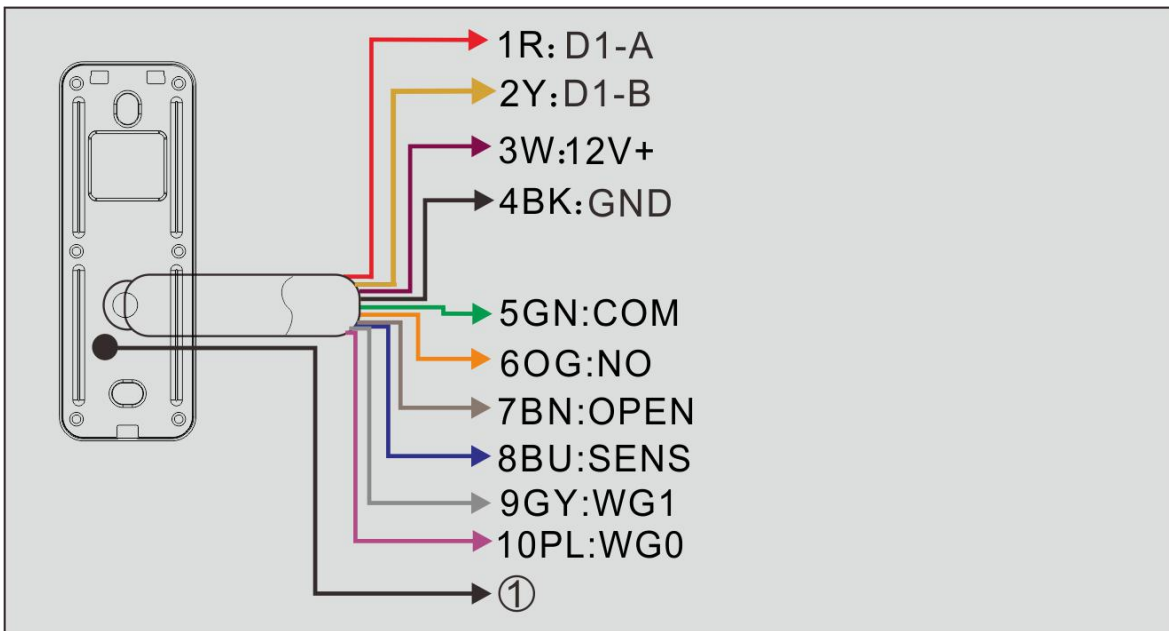

Wire NO.	Color	Description
1	Red	For connecting indoor monitor
2	Yellow	
3	White	For connecting door lock.
4	Black	
5	Green	For connecting gate lock
6	Orange	
7	Brawn	For connecting exit button
8	Blue	For connecting door status detection sensor.
9	Gray	Wiegand Data Output 1
10	Purple	Wiegand Data Output 0

① Password Reset Button

Reboot the door station, then press and hold on the reset button within 1 minute. The password resets successfully after two beeps.

3. Packing List

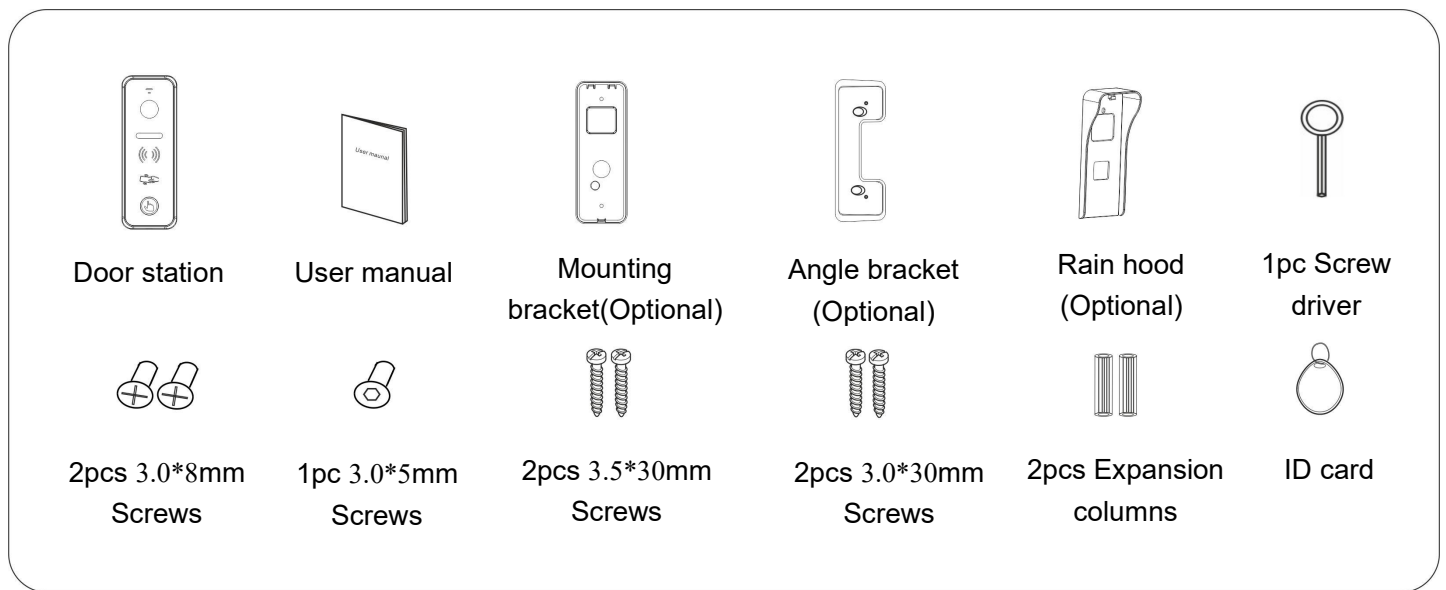

4. Wiring Diagram

4.1 Electrical Lock Wiring Diagram

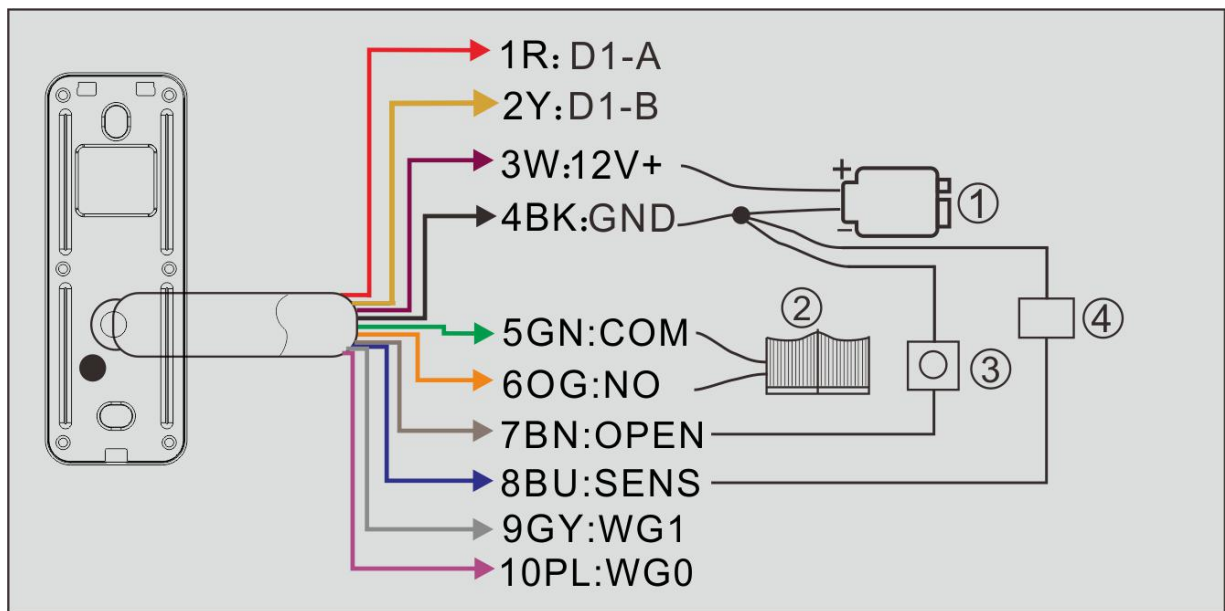

① Door lock

Support Door Lock Type:

A: NO (normal open) lock, power on to unlock. Support lock of DC12V current $\leq 2A$ (instantaneous).

B: NC (normal close) lock, power off to unlock. Support lock of DC12V 0.35A (Max).

② Gate lock

Support Gate Lock Type (It gives a reply signal for unlocking.):

A: AC Lock: Support lock of AC125V current \leq 1A

B: DC Lock: Support lock \leq DC30V, current \leq 4A

Remark:

Lock Type and Unlock Time Setting:

Touch “Device configuration” in the System Setting menu of 2-wire indoor monitor to enter the “Doorbell list”, select the door station, then enter the “Add to monitoring devices list” menu, choose the “Modify” to input the correct password and enter the modification interface, select the lock type to set the State to be ON or OFF, and set “Unlock Time” according to the actual needs.

③ Exit Button

Unlock button, which installed inside the door, when press this button it can open the door or gate.

④ Door status detection sensor

Set up of door status detection function: In the System Setting menu of 2-wire indoor monitor, touch “Device configuration” to enter the “Doorbell list”, select the door station, enter the menu of “Add to monitoring devices list”, select the “Modify” to input the correct password, then enter the modification interface, enable “Check door state”. Set “magnetic contact node type” to “Normal open” or “Normal close” according to actual needs. Set “Longest door open time”. Once the door is open, the door station will detect the door state after it reaches longest door open time. If the door is not closed after the longest door open time, the door station will alarm with beep sound.

4.2 Wiegand Unlock Wiring Diagram

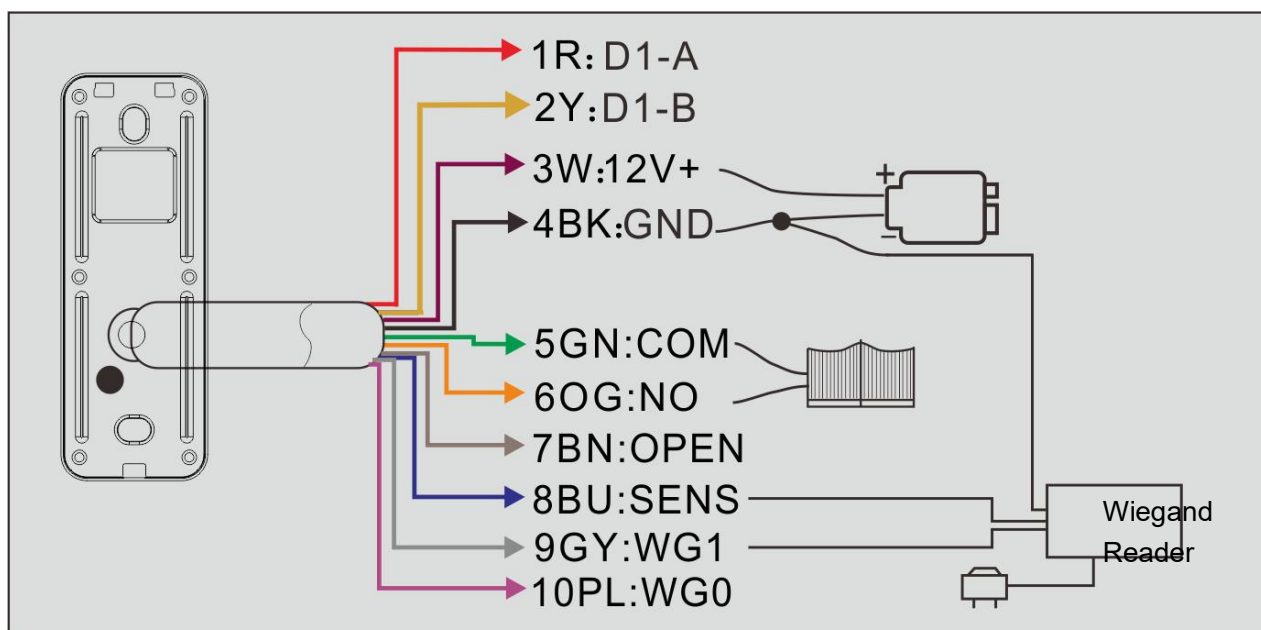

4.3 System Wiring Diagram

4.31 Use DC24V, 1A Adapter as System Power Supply

4.311 One Monitor with One Door Station

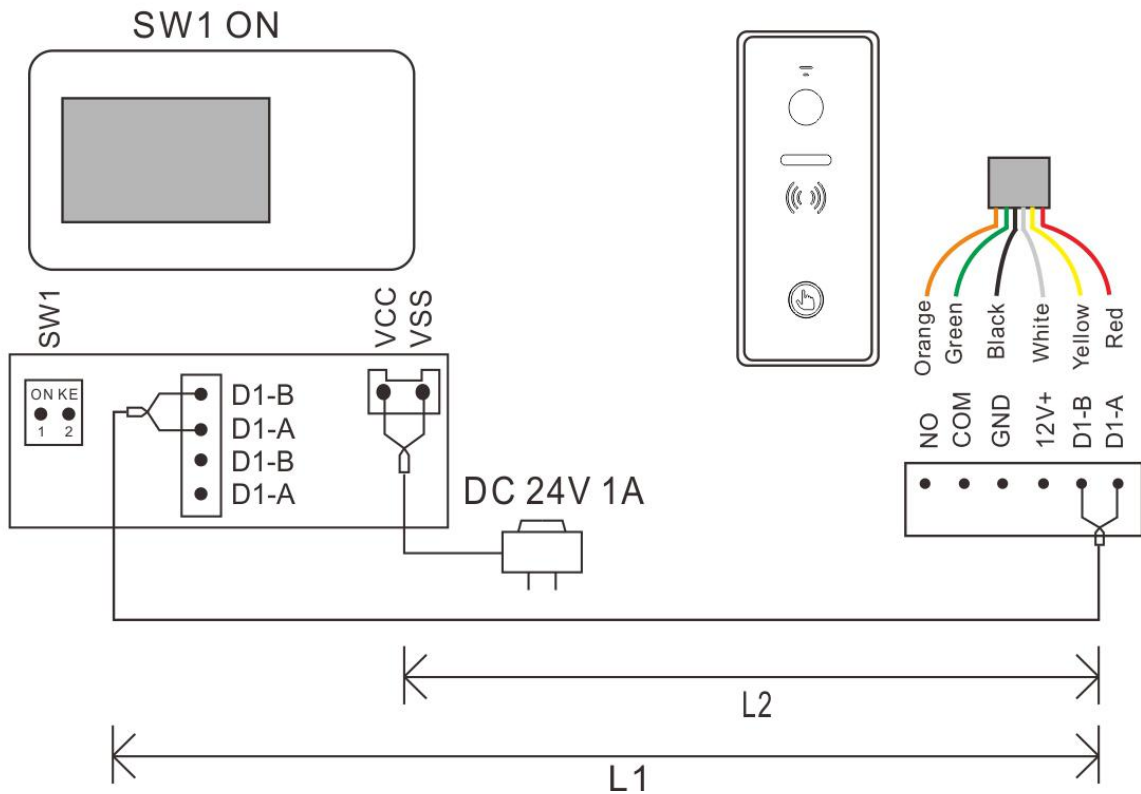

4.312 Two Monitors with One Door Station

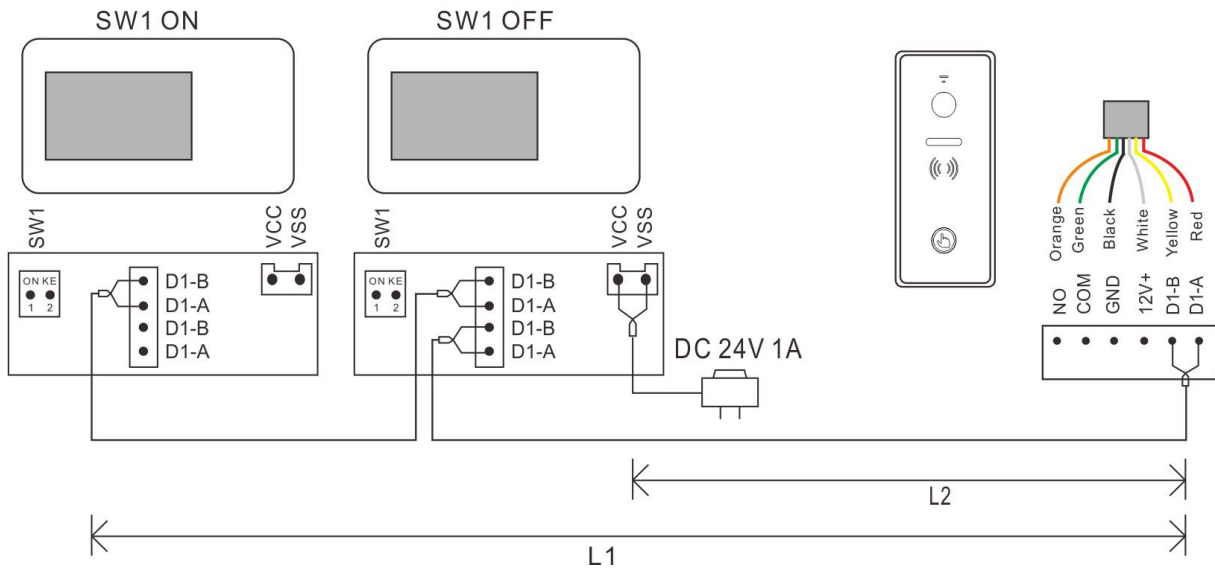

4.313 Four Monitors with One Door Station(Maximum)

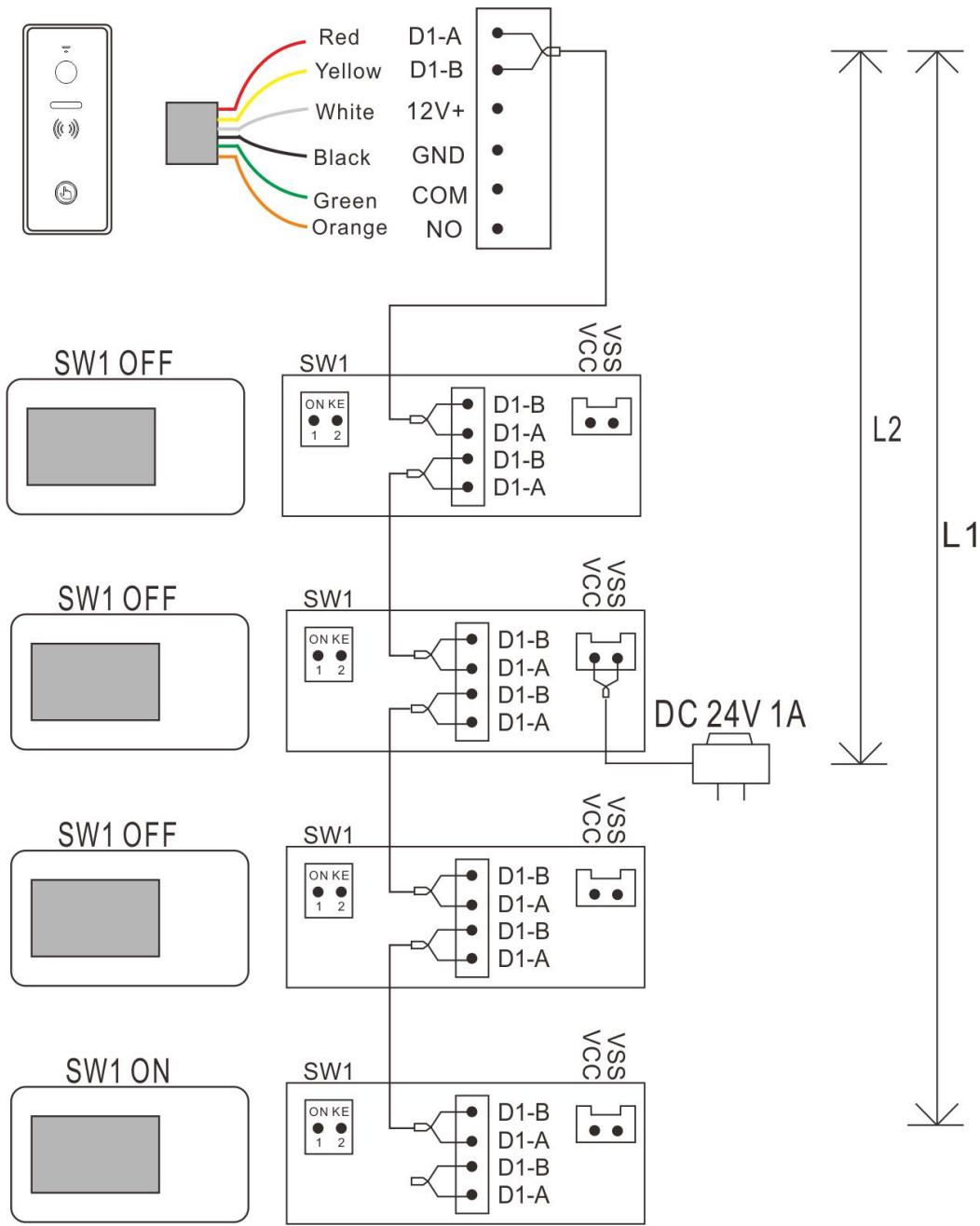

4.314 Three Monitors with Two Door Stations(Maximum)

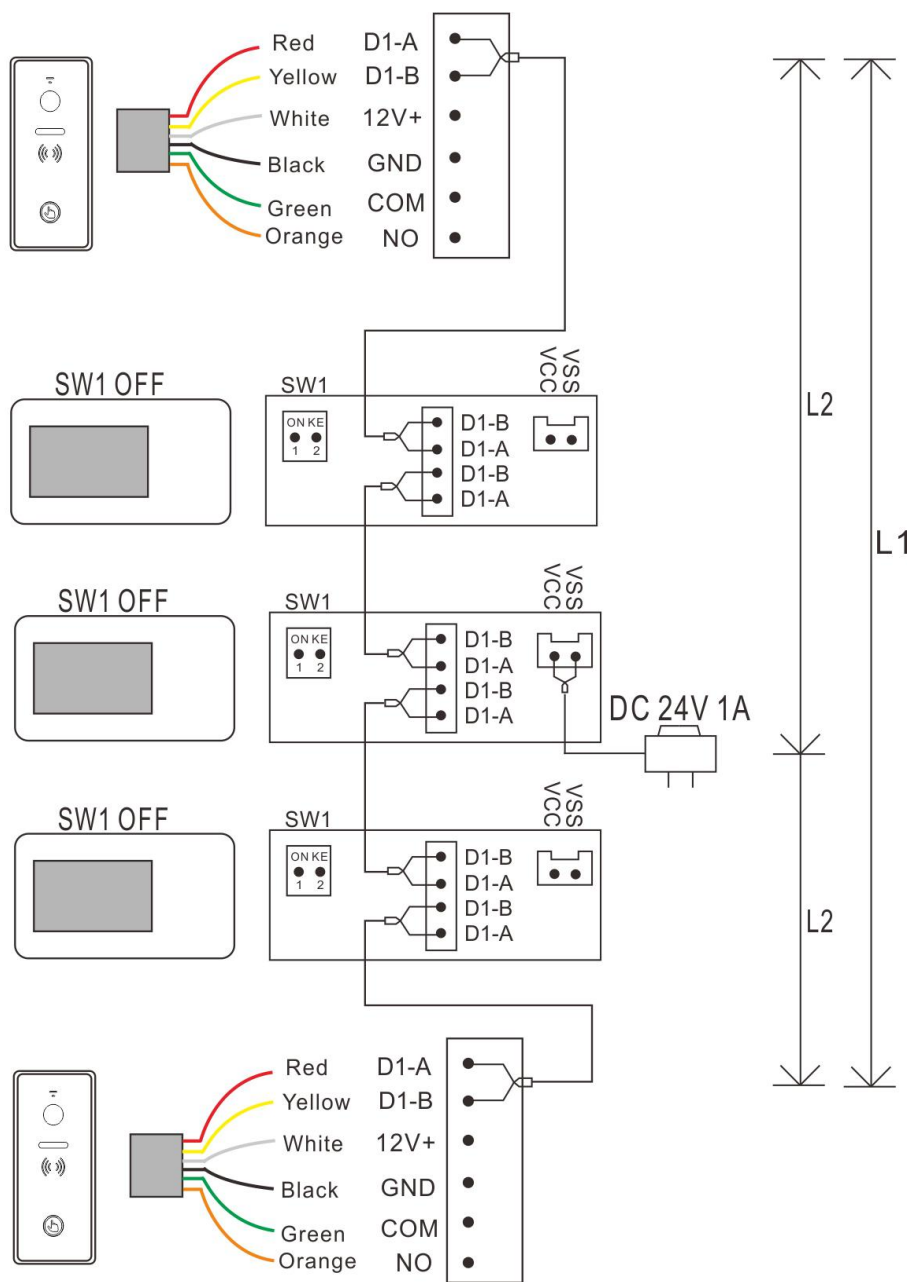

Remark:

- (1) All cables must be unshielded.
- (2) The same BUS should use the same wire with same specification.
- (3) Each system can only use 1 adapter power supply. If connect more than 1 adapter power supply, it may cause short circuit and system problem.
- (4) 2-wire BUS terminal match setting: The last monitor on 2-wire BUS should set SW1 to be ON as below picture ①. The other monitors should set SW1 to be OFF as below picture ②.

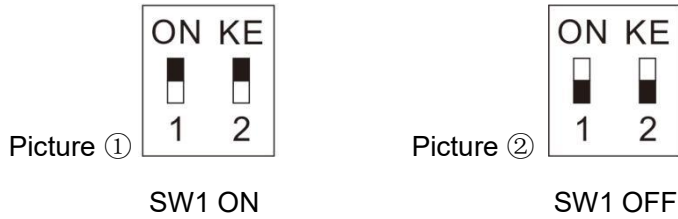

SW1 DIP Switch is ON by default.

(4) For above wiring (4.312) to (4.314), the ROOM ADDRESS in all monitors must be set to the same. All monitors will chime together when pressing the call button on door station.

(5) L1 represents the length of the BUS.

(6) For the total length limit of BUS, please refer to the Wire Distance.

(7) The BUS has no polarity.

(8) The default address of the monitor is 1, and the door station can call directly to the monitor after installation. But if you have changed the address of the monitor, you need to set the BUTTON ADDRESS for the door station.

Operation method:

Touch “Device configuration” in the System Setting menu of 2-wire indoor monitor to enter the “Doorbell list”, select the door station needs to set , then enter the “Add to monitoring devices list” menu, choose the “Modify” to input the correct password and enter the modification interface. Go to “Button Address” to set call target for the button.

4.32 Use DC24V, 1A DIN Rail Power as System Power Supply

4.321 One Monitor with One Door Station

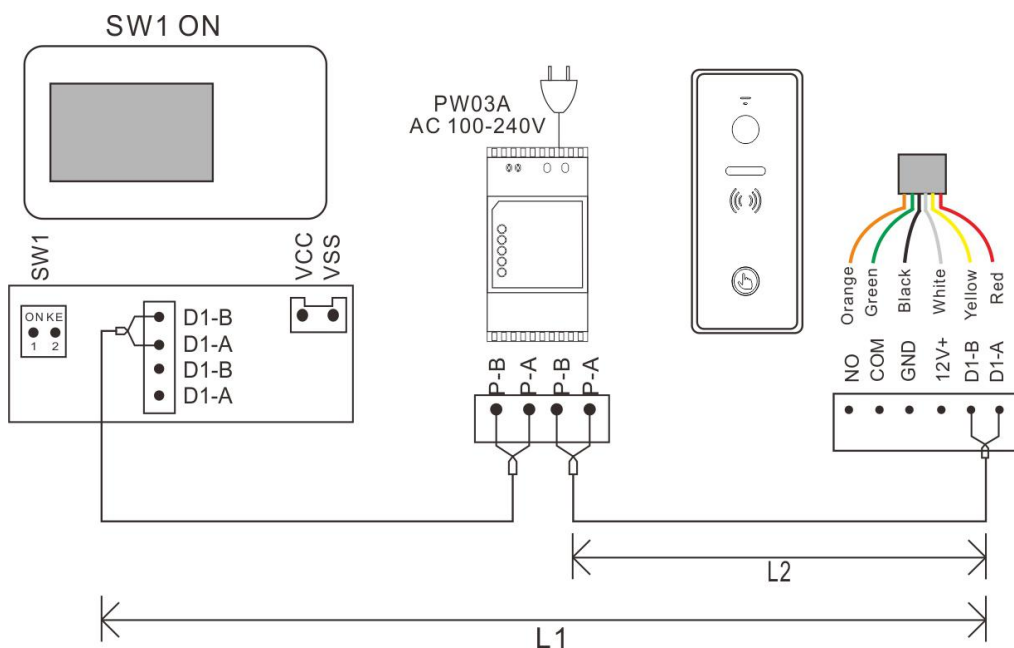

4.322 Two Monitors with One Door Station

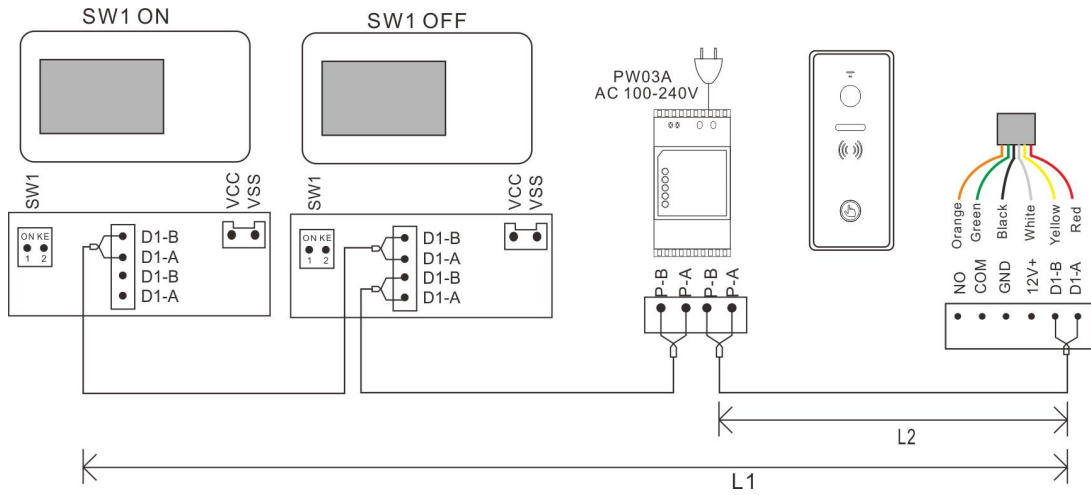

4.323 Four Monitors with Two Door Station(Maximum)

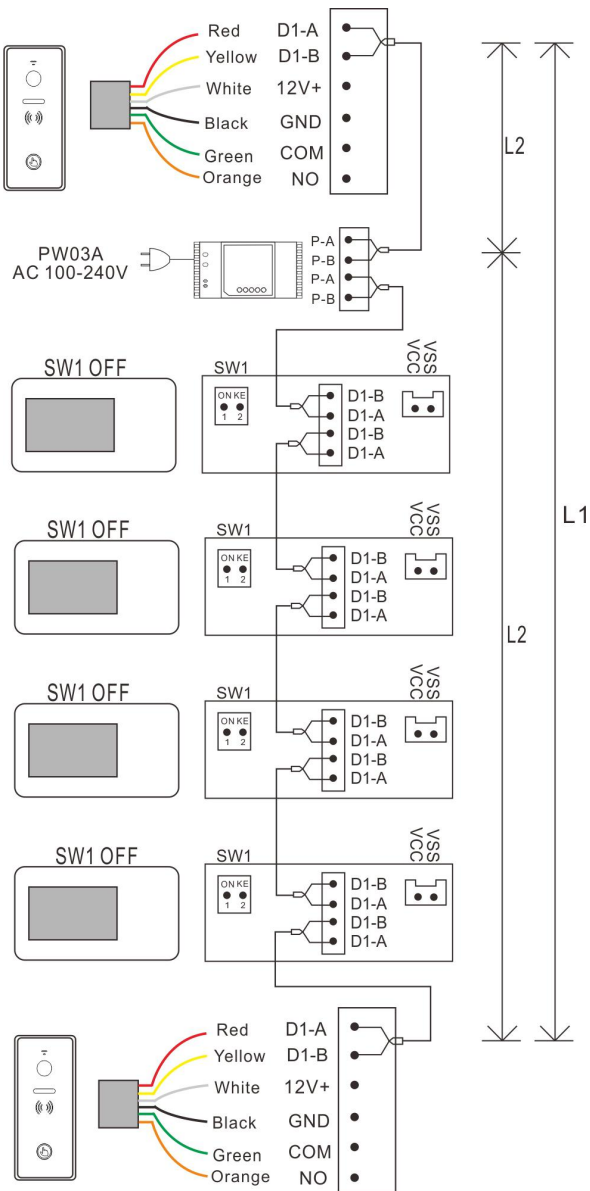

4.324 Five Monitors with One Door Station(Maximum)

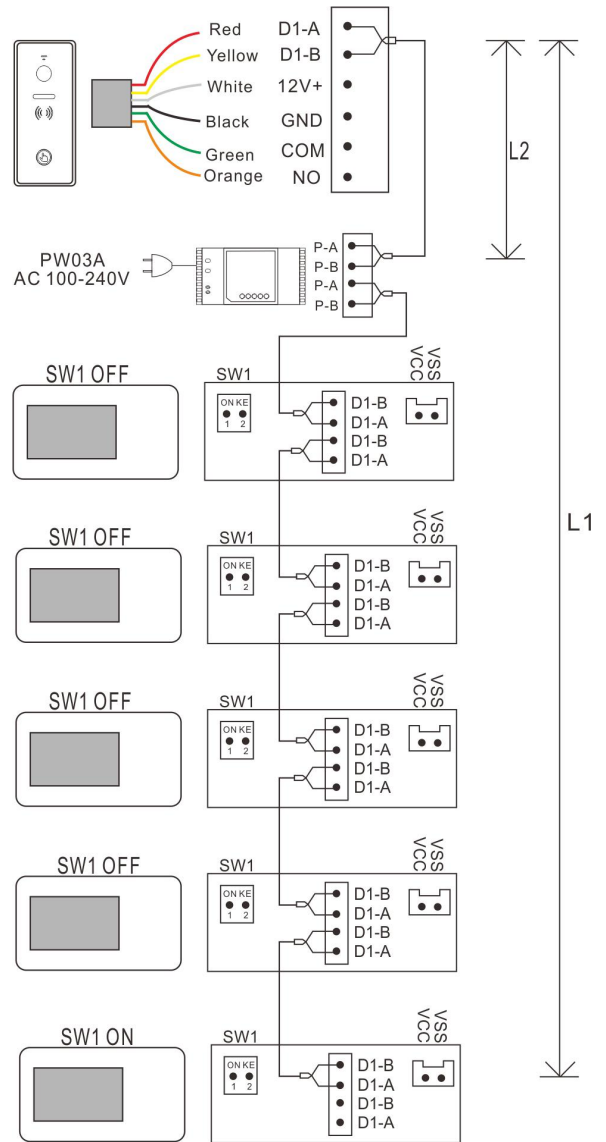

Remark:

- (1) All cables must be unshielded.
- (2) The same BUS should use the same wire with same specification.
- (3) 2-wire BUS terminal match setting: The last monitor on 2-wire BUS should set SW1 to be ON as below picture ①. The other monitors should set SW1 to be OFF as below picture ②.

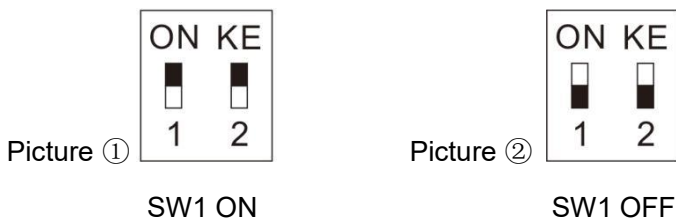

SW1 DIP Switch is ON by default.

- (3) For above wiring (4.322) to (4.324), the ROOM ADDRESS in all monitors must be set to the same. All monitors will chime together when pressing the call button on door station.
- (4) L1 represents the length of the BUS.
- (5) For the total length limit of BUS, please refer to the Wire Distance.
- (6) The BUS has no polarity.
- (7) The default address of the monitor is 1, and the door station can call directly to the monitor after installation. But if you have changed the address of the monitor, you need to **set the BUTTON ADDRESS for the door station.**

Operation method:

Touch “Device configuration” in the System Setting menu of 2-wire indoor monitor to enter the “Doorbell list”, select the door station needs to set , then enter the “Add to monitoring devices list” menu, choose the “Modify” to input the correct password and enter the modification interface. Go to “Button Address” to set call target for the button.

4.33 Multi Door Stations Connection

4.331 Three Door Stations Connect by a PW03C

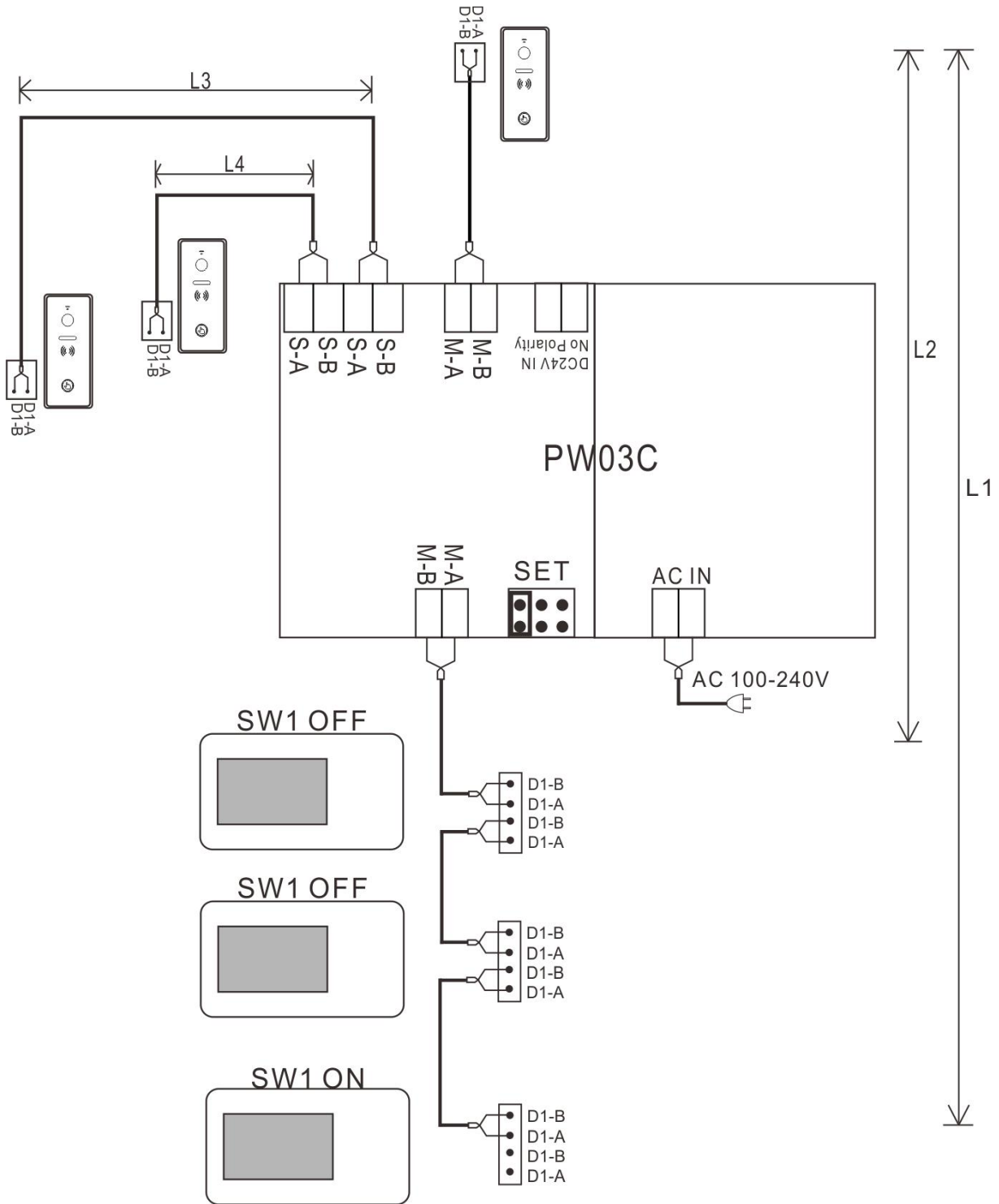

4.332 Three Door Stations Connect by a PW03B

(1) An External Power Supply for PW03B

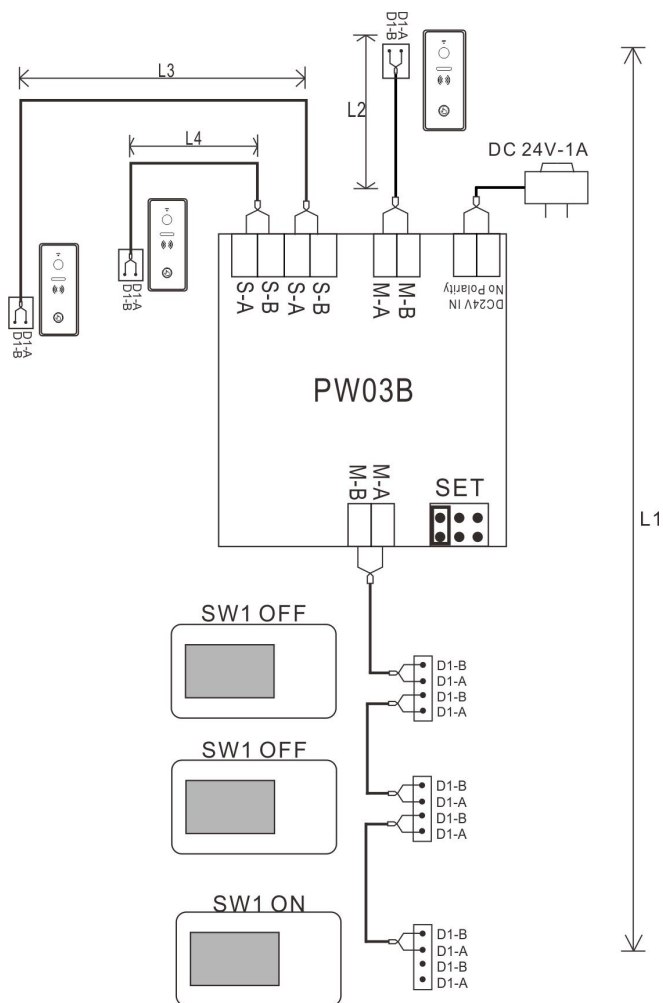

(2) Power Supply from 2 Wire BUS by a PW03A

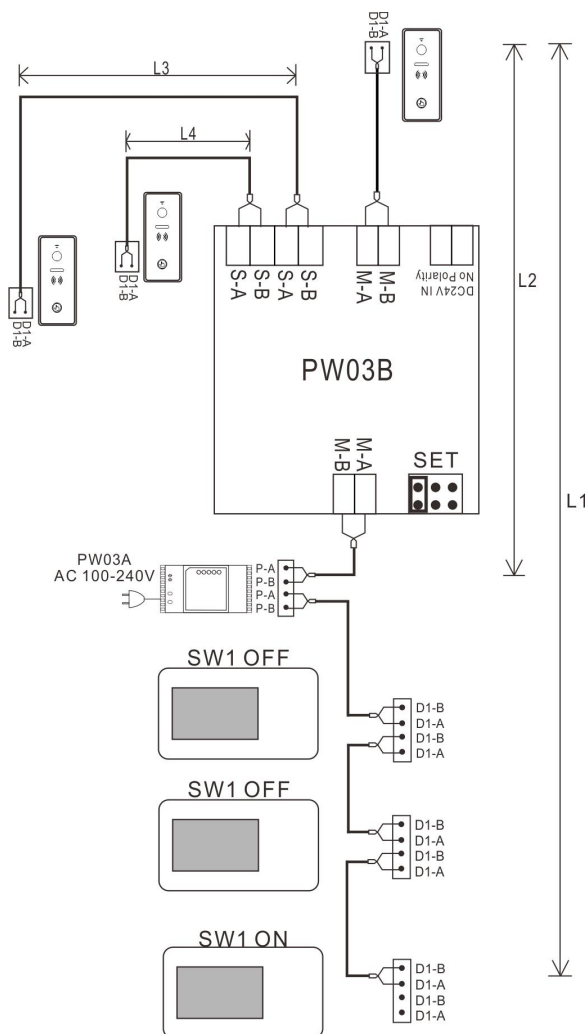

Remark:

- (1) All cables must be unshielded.
- (2) For the above 3 diagrams, the jumpers on PW03B and PW03C must be set as same as in the diagram.
- (3) If only connect 2 door stations, one of the door stations must connect to M-A and M-B.
- (4) L1 means the 2 wire BUS length.
- (5) L2 means the distance from the door station to the power supply.
- (6) L3 & L4 means the distance from the door station to PW03B or PW03C, and $L3 + L4 \cong L1$.
- (7) For above wiring (4.331) to (4.332), the ROOM ADDRESS in all monitors must be set to the same. All monitors will chime together when pressing the call button on door station.
- (8) 2-wire BUS terminal match setting: The last monitor on 2-wire BUS should set SW1 to be ON as below picture ①. The other monitors should set SW1 to be OFF as below picture ②.

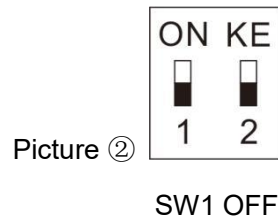
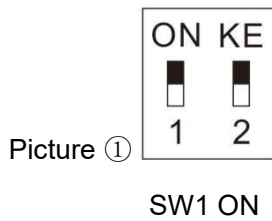

SW1 DIP Switch is ON by default.

5. Installation Guide

5.1 Cautions

(5.11) Choosing a suitable position for installation to avoid direct sunlight and rain.

(5.12) Suggest installation height: 1.5~1.6Meters.

(5.13) Ensure no power supply before installation finished.

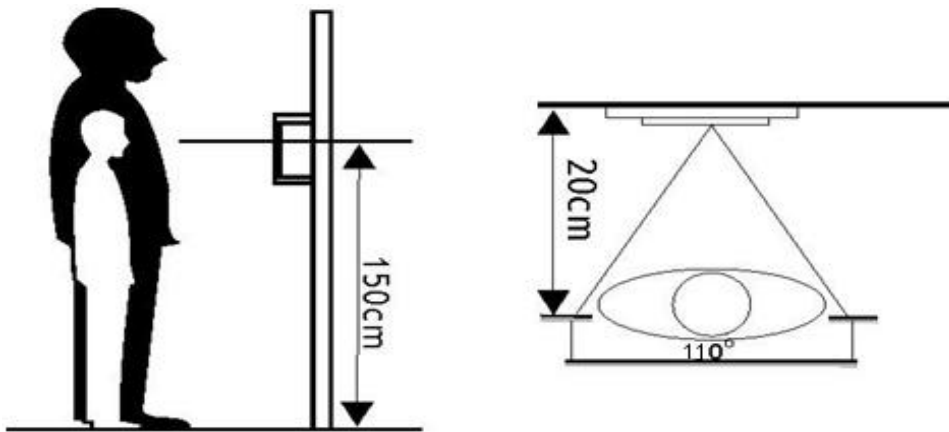

5.2 Surface Mounted

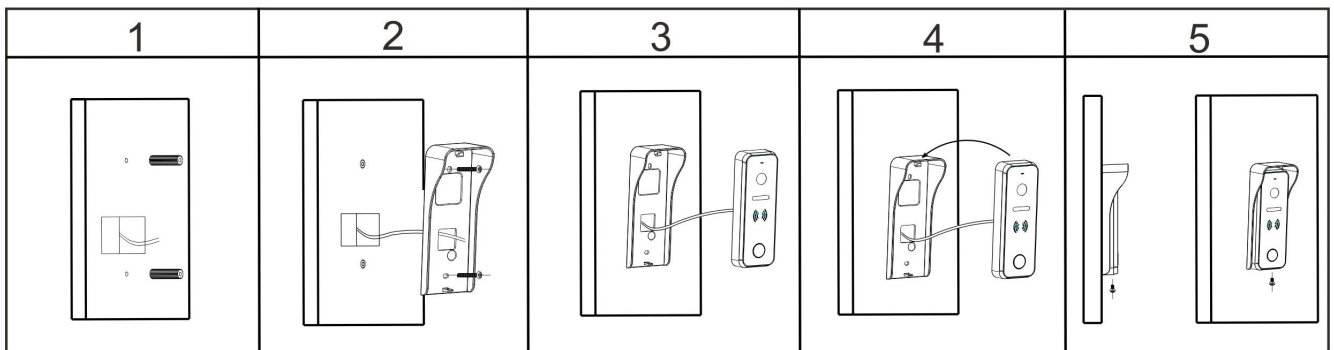

(1) Drill 2 holes according to the rain hood position, then insert the expansion columns into the holes.

(2) Let the cable go through the hole on the rain hood, then fix the rain hood to wall with 2 screws.

(3) Connect the cable according to the system wiring diagram.

(4) Clip the door station onto the rain hood.

(5) Fix the door station with the screw on the bottom.

5.3. Surface mounted with angle bracket (tilted 30°)

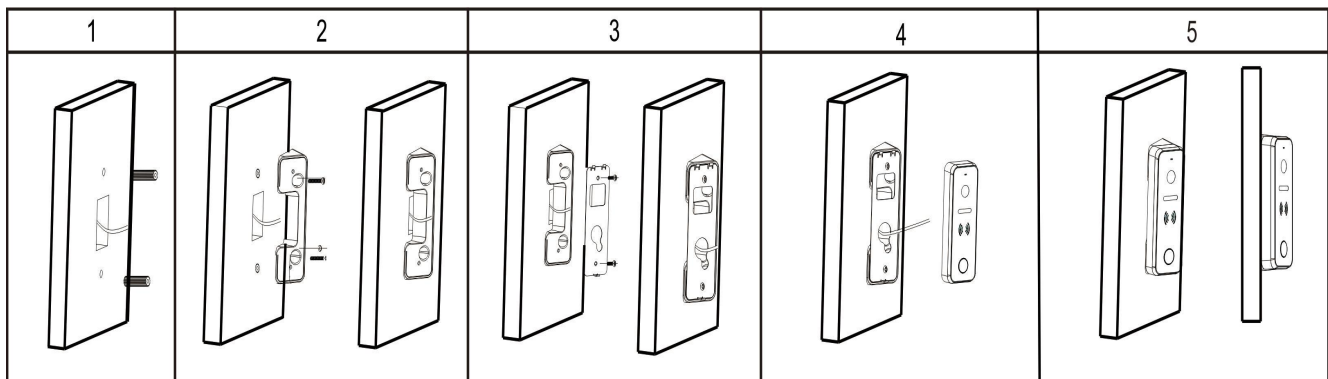







- (1) Drill 2 holes according to the angle bracket position, then insert the expansion columns into the holes.
- (2) Fix the angle bracket onto the wall with 2 screws.
- (3) Fix the mounting bracket onto the angle bracket with 2 screws.
- (4) Connect the cable according to the system wiring diagram.
- (5) Clip the door station onto the mounting bracket and secure with the bottom screw.

5.4 Wire Distance

Remark:

- (1) All cables must be unshielded.
- (2) Unlock distance L2 means the distance from the 1st door station to the system power supply.
- (3) Intercom distance L1 means the total distance of 2 wire BUS.
- (4) The same BUS should use the same wire with same specification.

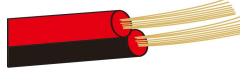
No.	Cable Type	DC24V 1A Adapter		PW03A DIN Rail Power	
		Intercom distance L1(m) (MAX)	Inner power unlock distance L2(m) (MAX)	Intercom distance L1(m) (MAX)	Inner power unlock distance L2 (m) (MAX)
1	Parallel pair cable (BVVB)2*0.5mm ² 	125	125	125	125
2	Parallel pair cable (BVVB) 2*0.75mm ² 	125	125	125	125
3	Twisted cable (ZC-RVS)2*0.5mm ² 	150	150	150	150
4	Twisted cable (ZC-RVS) 2*0.75mm ² 	150	150	150	150
5	Single pair cable (Standard CAT-5) 	150	100	150	100
6	Double pair cable (Standard CAT-5) 	200	150	200	150
7	Telephone line (HBV) 2*0.2mm ² 	50	50	50	50
8	Parallel pair cable 2*0.3 mm ² 	100	100	100	100

6 RFID Access Control Management

At standby state, read a registered card at the door station, the door will be open after a beep.

If you want to **open the gate lock**, press and hold on the call button on the door station, the button light will be on, read a registered card within 3 seconds, the gate lock will be open.

If read a unregistered card at the door station, there will be 2 beeps to remind you that it's invalid card.



Touch SETTING icon on Main Menu to enter SETTINGS interface, then touch DEVICE CONFIGURATION, then touch DOORBELL LIST. Touch the Door Station you want to change the settings, touch MODIFY, input password and # to enter MODIFY interface. Touch ACCESS CONTROL MANAGEMENT to do the below settings:

6.1 Access State

It's on by default. If users do not want to use card access control function, please disable this item.

6.2 Register Access Card(125KHz ID card)

Touch it, the screen will display below message: Please show your card to the door panel.....

At such state, the user can register new cards at the door station. When the user shows a new ID card to the card reading area on the door panel, the card will be registered after a beep. Same operation to add more access cards. After registered all the cards, please exit REGISTER ACCESS CARD interface.

Remark: The registered card information is save in the door station, so you can mange it at any indoor monitor which connects to the door station. If it's a private door station, it can only be managed by its call target monitors.

6.3 Check/Manage Registered Card Information

All the registered access card information could be found in VALID REGISTERED CARD LIST. Touch any registered card to enter a sub menu, then you can edit the card information.

MAIN INDEX can be a room no. or any easily remember no. for one family.

SUB INDEX can be a series no. for registered card of one family.

If you want to pause one access card, touch MOVE TO INVID REGISTERED CARD LIST.

If you want to delete one access card, touch DELETE ACCESS CARD.

If you want to delete all registered card information, touch DELETE ALL REGISTERED CARD INFORMATION.

6.4 Backup Registered Card Information

Insert a micro SD card into the indoor monitor. Then go to ACCESS CONTROL MANAGEMENT, touch BACKUP REGISTERED CARD INFORMATION, a sub menu will appear, touch CONFIRM to start backup. When backup finished, it will go back to ACCESS CONTROL MANAGEMENT interface.

6.5 Restore Registered Card Information

Insert the micro SD card, which has registered card backup information, into the indoor monitor. Then go to ACCESS CONTROL MANAGEMENT, touch RESTORE REGISTERED CARD INDORMATION. Choose

ACCESS DATE folder, a sub menu will appear, touch  to restore registered card information.

7. Specification

No	Item	Content
1	Communication	Digital 2 wire
2	Subscribers quantity	1 subscriber / 2 subscribers
3	Audio	Digital audio (bidirectional)
4	Video	1 channel digital video (output)
5	Camera	1080P HD color CMOS camera
6	Night vision	Infrared light(with automatic lumens adjustment)
7	Effective distance (0 Lux)	0.5 meter
8	Viewing angle	Horizontal 110 degree, Vertical 50 degree
9	Buttons	1 mechanical buttons
10	Working voltage	DC12V-24V 0.3A MAX
11	Support electrical lock	NC Lock of DC12V 0.35A (Max), or NO Lock of DC12V $\leq 2A$ (instantaneous).
12	Support gate lock	One unlock signal (dry contact). (1): AC Lock: Support lock of AC125V current $\leq 1A$ (2): DC Lock: Support lock $\leq DC30V$, current $\leq 4A$
13	Unlock control	Signal instruction
14	Support card type	ID card(125KHz)
15	Card reading distance	$\leq 20mm$
16	Support card number	1000pcs
17	Power consumption	3W
18	Working temperature	-25°C- +60°C
19	Storage temperature	-30°C- +60°C
20	Dimensions	Without rain hood: 137*49*20mm With rain hood: 142*56*34mm
21	IP Grade	IP66
22	IK Grade	IK07

Products are subject to change without prior notice.

50600341